

# 545

## Circular Nylon Cable Chain with opening frames

**Inner height (D) 46 mm**  
 Double share Sideband & Frame construction with large anti-friction single-pin.  
 Frames opening from inner radius.

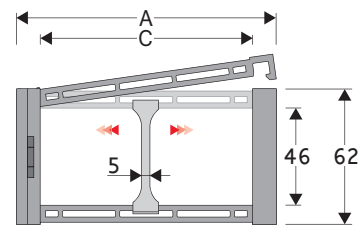

Separator	
- Unassembled	Part.no S445UF
- Assembled	Part.no S445UFMC
Pin	
	Part.no PG545

Technical characteristics	
Speed	180°/s
Acceleration	180°/s <sup>2</sup>

For higher requirements please consult our technical dept.

A	B	C	D	R	Weight/pitch	Chain
mm	mm	mm	mm	mm	kg	Part Number
123	62	100	46	100	0,200	545SI100100

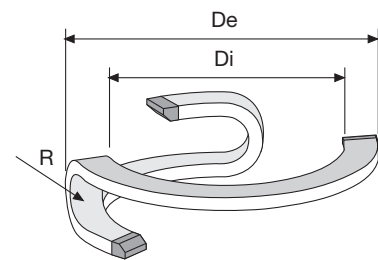

R	Di	De
mm	mm	mm
100	485	760

Length of Chain		
Chain Part Numbers	Degrees of Rotation	No of Pitches
545	90	14
545	180	18
545	270	22
545	360	27



### Steel End Brackets

The end brackets set, containing two steel plates screwed to the links, allows the two ends of the chain to be attached to the equipment. The end brackets are installed in one position offering the possibility of attaching the chain externally. (Fig. A)

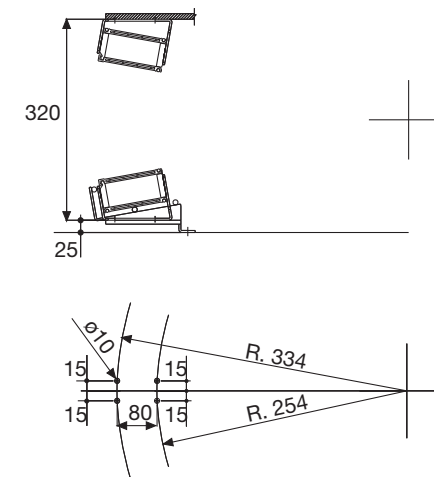

Fig. A

### Support Guide

For correct functioning of the chain it is necessary that the installation is done in a specific position. For this reason Brevetti Stendalto has observed and created a support guide which can do this. (Fig. B)  
 For particular applications it is possible to create support guides with attachment plates and special dimensions.

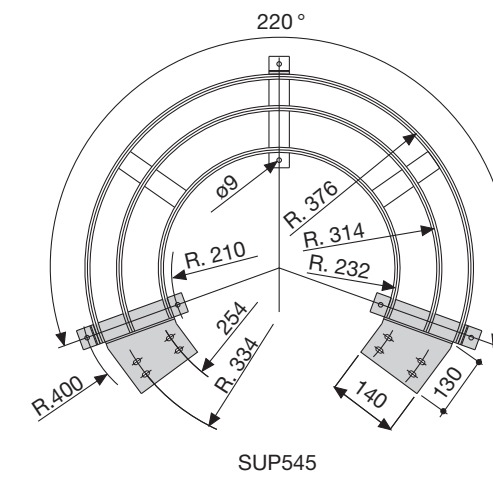

Fig. B

### Steel End Brackets Part Numbers

Complete Set Assembled	
Chain Type	End Brackets Set
545	A545KM
Complete Set Unassembled	
Chain Type	End Brackets Set
545	A545K

For applications with rotations exceeding 200° it is necessary to use the appropriate accessories for supporting the cable chain. (see page 29).

# 545

## Circular Nylon Cable Chain with opening frames

