

## 478PU Nylon Cable Chain with opening frames

### Inner height (D) 75,5 mm

Sideband & Frame construction with large anti-friction single-pin. Covers are opening from inner radius or from outer radius. Vertical and horizontal modular separator system are available.

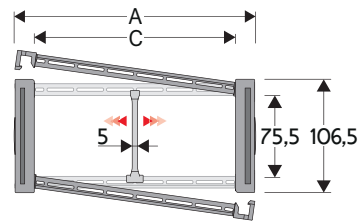

Separator	
- Unassembled	Part.no S309S/3178
- Assembled*	Part.no S309S/3178MCI
- Assembled**	Part.no S309S/3178MCE
Pin	
	Part.no PG475

\* for chain opening outer radius  
\*\* for chain opening inner radius

### Technical characteristics

Speed	3 m/s
Acceleration	8 m/s <sup>2</sup>

For higher requirements please consult our technical dept.

A	B	C	D	R	Weight/m	Chain
mm	mm	mm	mm	mm	kg	Part number
112	106,5	74	75,5	180-200-250-300-350-400	4,60	478PU074 □□□ *
132	106,5	94	75,5	180-200-250-300-350-400	4,80	478PU094 □□□ *
157	106,5	119	75,5	180-200-250-300-350-400	5,10	478PU119 □□□ *
164	106,5	126	75,5	180-200-250-300-350-400	5,15	478PU126 □□□ *
187	106,5	149	75,5	180-200-250-300-350-400	5,40	478PU149 □□□ *
227	106,5	189	75,5	180-200-250-300-350-400	5,80	478PU189 □□□ *
262	106,5	224	75,5	180-200-250-300-350-400	6,20	478PU224 □□□ *
288	106,5	250	75,5	180-200-250-300-350-400	6,50	478PU250 □□□ *
312	106,5	274	75,5	180-200-250-300-350-400	6,75	478PU274 □□□ *
338	106,5	300	75,5	180-200-250-300-350-400	7,05	478PU300 □□□ *
362	106,5	324	75,5	180-200-250-300-350-400	7,30	478PU324 □□□ *
388	106,5	350	75,5	180-200-250-300-350-400	7,55	478PU350 □□□ *
412	106,5	374	75,5	180-200-250-300-350-400	7,85	478PU374 □□□ *
467	106,5	429	75,5	180-200-250-300-350-400	8,50	478PU429 □□□ *
536	106,5	498	75,5	180-200-250-300-350-400	9,20	478PU498 □□□ *

\*Complete the code by inserting the value of the radius (R): Ex. 478PU119 □1□5□□

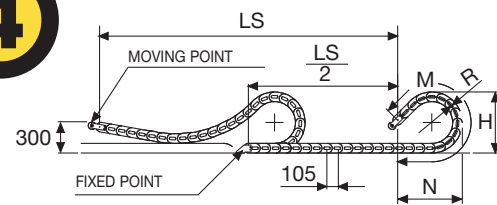

Length of chain (L)  
Half travel distance ( $\frac{LS}{2}$ )  
plus length of curve (M)

$$L = \frac{LS}{2} + M$$

R	H	N	M
mm	mm	mm	mm
180	466,5	495	1155
200	506,5	570	1330
250	606,5	745	1765
300	706,5	920	2205
350	806,5	1090	2640
400	906,5	1265	3080



### End Brackets

The end brackets set allows the two ends of the chain to be attached to the equipment. One set includes two pivoting end brackets to be installed at the moving point and two standard steel end brackets to be installed at the fixed point.

**Bright Zinc Plated Steel Movable Type\*\*\***    **Bright Zinc Plated Steel Type\*\*\* (moving point) (fixed point)**

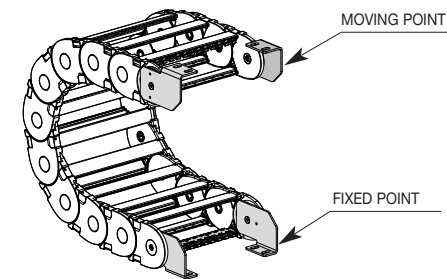
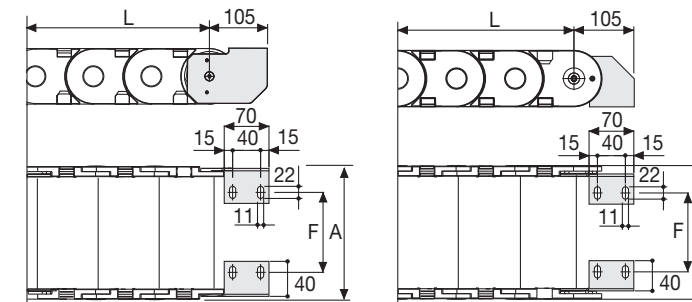

Fig. A  
Chain fixed outside the radius. (Fig A)



Chain Type	F mm
478PU074	35
478PU094	55
478PU119	80
478PU126	87
478PU149	110
478PU189	150
478PU224	185
478PU250	211
478PU274	235
478PU300	261
478PU324	285
478PU350	311
478PU374	335
478PU429	390
478PU498	459

### Bright Zinc Plated Steel Type Part Numbers

Complete Set Assembled Chain Type	End Brackets Set
478PU...	A478KM□**

Complete Set Unassembled Chain Type	End Brackets Set
478PU...	A478K

Tiewrap Clamp	Part Number
---------------	-------------

Assembled CFC478M□□□\*KM  
Unassembled CFC478M□□□\*K

\* Inner width (C)  
\*\* 1=Pos.1; 2=Pos.2  
\*\*\* Available on request in stainless steel

## 478PU Nylon Cable Chain with opening frames

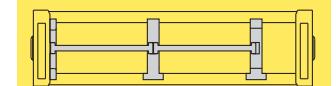

Separation System  
To choose the separators see page. 216

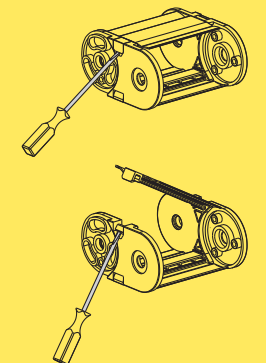

How to open the cover.

For further information please consult Brevetti Standalto's Technical Office