

329CD Nylon Sliding Cable Chain with opening aluminium covers

Inner height (D) 75,5 mm

Strong double share Sideband & Frame construction with large anti-friction triple-pin. The chain incorporates large sliding-skid surfaces to offer durability, even with high speed/loads. Aluminium covers are opening from inner radius or outer radius.

Vertical separators are available

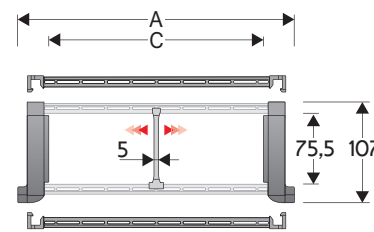

Separator	
- Unassembled	Part.no S309S/3178
- Assembled	Part.no S309S/3178MCI for chain opening outer radius
- Assembled	Part.no S309S/3178MCE for chain opening inner radius
Pin	
	Part.no PG329

Technical characteristics

Speed	3 m/s
Acceleration	13 m/s ²

For higher requirements please consult our technical dept.

A	B	C	D	R	Weight/m	Chain
mm	mm	mm	mm	mm	kg	Part Number
148	107	84	75,5	200-250-300-350-400-500-600	5,70	329CD084 □□□*
173	107	109	75,5	200-250-300-350-400-500-600	6,11	329CD109 □□□*
180	107	116	75,5	200-250-300-350-400-500-600	6,24	329CD116 □□□*
203	107	139	75,5	200-250-300-350-400-500-600	6,62	329CD139 □□□*
243	107	179	75,5	200-250-300-350-400-500-600	7,33	329CD179 □□□*
278	107	214	75,5	200-250-300-350-400-500-600	7,96	329CD214 □□□*
304	107	240	75,5	200-250-300-350-400-500-600	8,40	329CD240 □□□*
328	107	264	75,5	200-250-300-350-400-500-600	8,80	329CD264 □□□*
354	107	290	75,5	200-250-300-350-400-500-600	9,26	329CD290 □□□*
378	107	314	75,5	200-250-300-350-400-500-600	9,68	329CD314 □□□*
404	107	340	75,5	200-250-300-350-400-500-600	10,12	329CD340 □□□*
428	107	364	75,5	200-250-300-350-400-500-600	10,55	329CD364 □□□*
483	107	419	75,5	200-250-300-350-400-500-600	11,73	329CD419 □□□*
552	107	488	75,5	200-250-300-350-400-500-600	12,91	329CD488 □□□*

*Complete the code by inserting the value of the radius (R): Ex. 329CD116 □□□□

R	H	N	M
mm	mm	mm	mm
200	506	595	1345
250	606	765	1780
300	706	940	2220
350	806	1110	2655
400	906	1280	3095
500	1106	1625	3970
600	1306	1965	4845

End Brackets

The end brackets set allows the two ends of the chain to be attached to the equipment. One set includes two pivoting end brackets to be installed at the moving point and two standard steel end brackets to be installed at the fixed point.

Bright Zinc Plated Steel Movable Type*** (moving point)

Bright Zinc Plated Steel Type*** (fixed point)

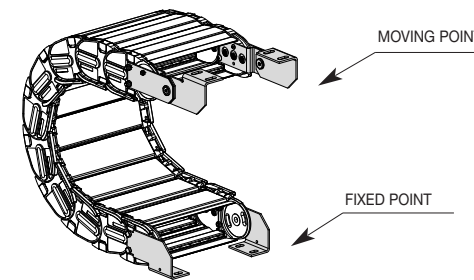
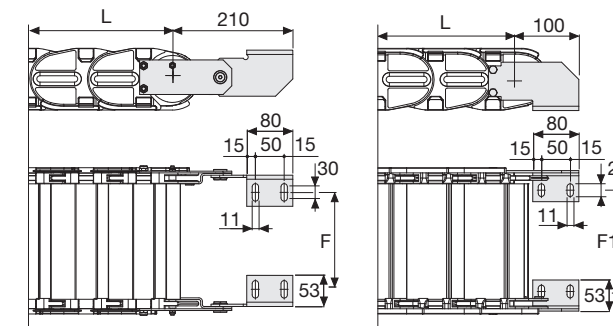

Fig. A
Chain fixed outside the radius. (Fig A)



Chain Type	F mm	Chain Type	F1 mm
329CD084	60	329CD084	71
329CD109	85	329CD109	96
329CD116	92	329CD116	103
329CD139	115	329CD139	126
329CD179	155	329CD179	166
329CD214	190	329CD214	201
329CD240	216	329CD240	227
329CD264	240	329CD264	251
329CD290	266	329CD290	277
329CD314	290	329CD314	301
329CD340	316	329CD340	327
329CD364	340	329CD364	351
329CD419	395	329CD419	406
329CD488	464	329CD488	475

Bright Zinc Plated Steel Type Part Numbers

Complete Set Assembled	End Brackets
Chain	Set
329SU..	A329CKM□**

Complete Set Unassembled	End Brackets
Chain	Set
329SU..	A329CD□□□*K

* Inner width (C)

** 1=Pos.1; 2=Pos.2; 3=Pos.3

*** Available on request in stainless steel

4

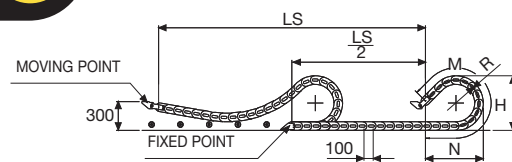

Length of chain (L)

Half travel distance ($\frac{LS}{2}$)

plus length of curve (M)

$$L = \frac{LS}{2} + M$$



329CD Nylon Sliding Cable Chain with opening aluminium covers

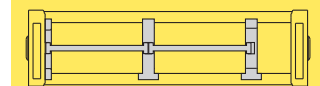

Separation System
To choose the separators see page. 216

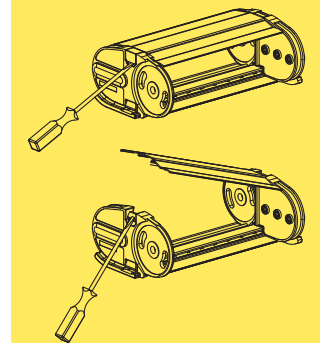

How to open the cover

For further information please consult Brevetti Stendalto's Technical Office

4