

Serie Heavy 309SU

Nylon Cable Chain with opening frames

Inner height (D) 75,5 mm

Strong double share Sideband & Frame construction with large anti-friction triple-pin. Frames opening from inner and outer radius.

As standard the chain comes with frames every second link, on request with frames every link.

Vertical and horizontal modular separator system is available.

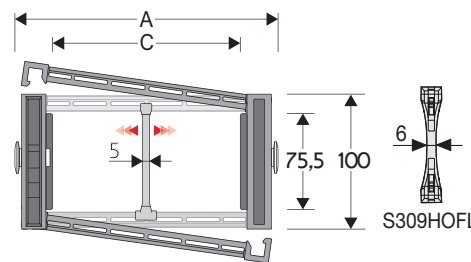

Separator	
- Unassembled	Part.no S309S/3178
- Assembled*	Part.no S309S/3178MCI
- Assembled**	Part.no S309S/3178MCE
Strong-hold separator	
for C > 250 mm	
- Unassembled	Part.no S309HOFL
- Assembled	Part.no S309HOFLMC
Pin	
	Part.no PG309H

* for chain opening outer radius
** for chain opening inner radius

Technical characteristics when self-supported

Speed	8 m/s
Acceleration	40 m/s ²

For higher requirements please consult our technical dept.

A	B	C	D	R	Weight/m	Chain
mm	mm	mm	mm	mm	kg	Part Number
117	100	64	75,5	150-200-250-300-350-400-500-600	4,03	309SU064□□□*
137	100	84	75,5	150-200-250-300-350-400-500-600	4,09	309SU084□□□*
162	100	109	75,5	150-200-250-300-350-400-500-600	4,17	309SU109□□□*
169	100	116	75,5	150-200-250-300-350-400-500-600	4,20	309SU116□□□*
192	100	139	75,5	150-200-250-300-350-400-500-600	4,27	309SU139□□□*
232	100	179	75,5	150-200-250-300-350-400-500-600	4,40	309SU179□□□*
267	100	214	75,5	150-200-250-300-350-400-500-600	4,51	309SU214□□□*
293	100	240	75,5	150-200-250-300-350-400-500-600	4,60	309SU240□□□*
317	100	264	75,5	150-200-250-300-350-400-500-600	4,67	309SU264□□□*
343	100	290	75,5	150-200-250-300-350-400-500-600	4,75	309SU290□□□*
367	100	314	75,5	150-200-250-300-350-400-500-600	4,83	309SU314□□□*
393	100	340	75,5	150-200-250-300-350-400-500-600	4,90	309SU340□□□*
417	100	364	75,5	150-200-250-300-350-400-500-600	4,99	309SU364□□□*
472	100	419	75,5	150-200-250-300-350-400-500-600	5,20	309SU419□□□*
541	100	488	75,5	150-200-250-300-350-400-500-600	5,40	309SU488□□□*

*Complete the code by inserting the value of the radius (R): Ex. 309SU116 □ □ □ □
Chain equipped with nylon frame every pitch: complete the code by inserting the letter D.
Ex. 309SU116250 □ □ □ □

R	H	N	M
mm	mm	mm	mm
150	406	300	675
200	506	350	830
250	606	400	985
300	706	455	1145
350	806	500	1300
400	906	555	1460
500	1106	650	1770
600	1306	750	2085

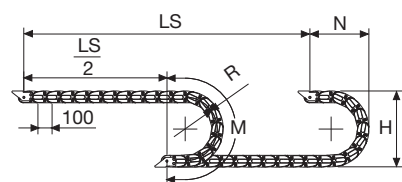

Length of chain (L)

Half travel distance ($\frac{LS}{2}$)

plus length of curve (M)

$$L = \frac{LS}{2} + M$$

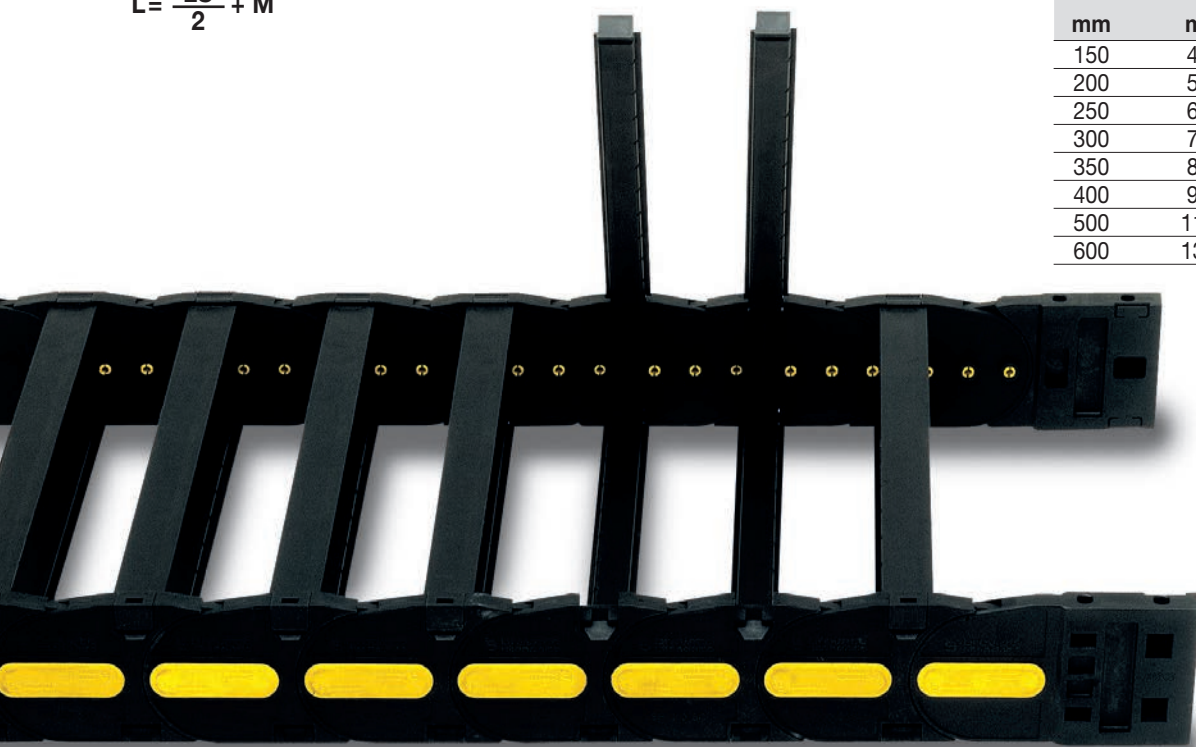

Version with frames mounted on every pitch.

Self-Supporting Capacity Diagram

The maximum length of the self-supporting capacity ($\frac{LS}{2}$) in relationship to the weight of the cables and hoses contained per linear metre.

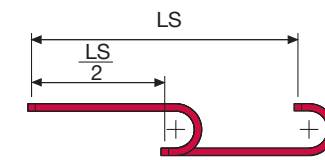
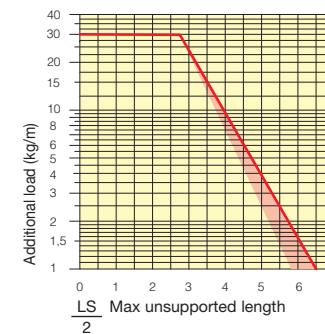

The red marking in the diagram area considers the difference of weight between various widths of chains assembled with nylon frames every second pitch.

For applications with $\frac{LS}{2}$ and weights not included in the area of the diagram showing self-supporting capacity, verify the possible use of support rollers (see page 30).

End Brackets

The end brackets set allows the two ends of the chain to be attached to the equipment. Set complete with tiwrap clamps available on request.

Nylon Type

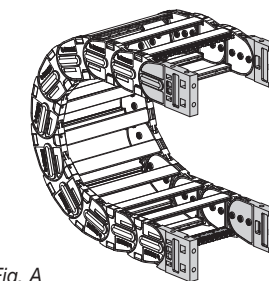
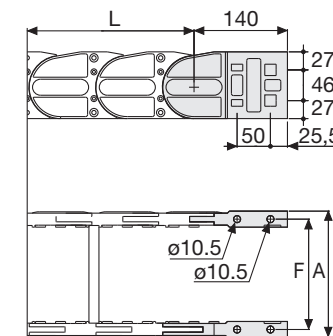

Fig. A
The chain can be fixed frontally, inner or outer radius. (Fig A)



Chain Type	F mm
309SU064	92
309SU084	112
309SU109	137
309SU116	144
309SU139	167
309SU179	207
309SU214	242
309SU240	268
309SU264	292
309SU290	318
309SU314	342
309SU340	368
309SU364	392
309SU419	447
309SU488	516

Nylon Type Part Numbers

Complete Set Assembled Chain Type	End Brackets Set
309SU...	AN309KM
Complete Set Unassembled Chain Type	End Brackets Set
309SU...	AN309K
Tiewrap Clamp	
Assembl.	CFC309S □□□*KM
Unassembl.	CFC309S □□□*K

Bright Zinc Plated Steel Type***

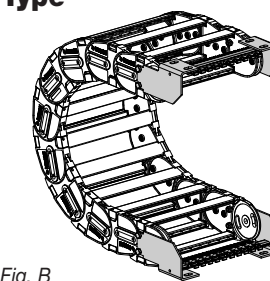
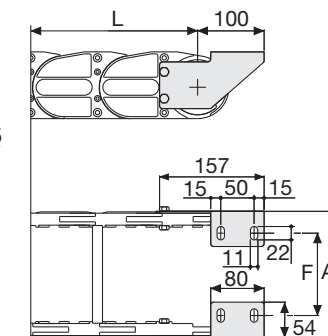

Fig. B
Chain fixed outside the radius. (Fig B)
See end brackets mounting variations page 31.



Chain Type	F mm
309SU064	50
309SU084	70
309SU109	95
309SU116	102
309SU139	125
309SU179	165
309SU214	200
309SU240	226
309SU264	250
309SU290	276
309SU314	300
309SU340	326
309SU364	350
309SU419	405
309SU488	474

Bright Zinc Plated Steel Type Part Numbers

Complete Set Assembled Chain Type	End Brackets Set
309SU...	A309SKM □□**
Complete Set Unassembled Chain Type	End Brackets Set
309SU...	A309SK □□**
Tiewrap Clamp	
Assembl.	SFCT309S □□□*KM
Unassembl.	SFCT309S □□□*K

* Inner width (C)
** 1=Pos.1; 2=Pos.2; 3=Pos.3
*** Available on request in stainless steel

Serie Heavy

309SU Nylon Cable Chain with opening frames

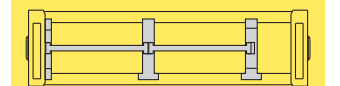

Separation System
To choose the separators see page. 216

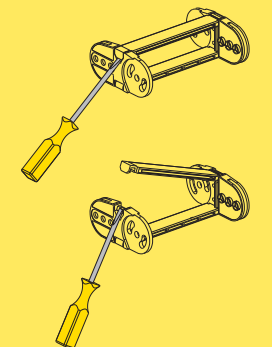

How to open the cover.

Protection version



Protection version
see page 156

For further information please consult Brevetti Stendalto's Technical Office