

# Serie Heavy 308SU

## Nylon Cable Chain with opening frames

### Inner height (D) 57 mm

Strong double share Sideband & Frame construction with large anti-friction triple-pin. Frames opening from inner and outer radius. As standard the chain comes with frames every second link, on request with frames every link. Vertical and horizontal modular separator system is available.

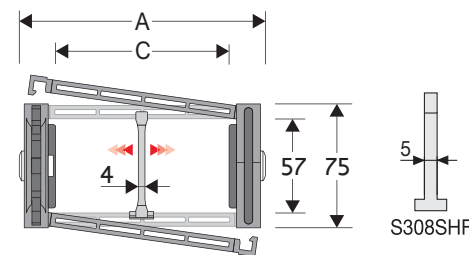

Separator	
- Unassembled	Part.no S308C
- Assembled*	Part.no S308CMCI
- Assembled**	Part.no S308CMCE
Strong-hold separator	
for C > 250 mm	
- Unassembled	Part.no S308SHF
- Assembled*	Part.no S308SHFMI
- Assembled**	Part.no S308SHFMCE
Pin	
	Part.no PG308

\* for chain opening outer radius  
\*\* for chain opening inner radius

### Technical characteristics when self-supported

Speed	8 m/s
Acceleration	40 m/s <sup>2</sup>

For higher requirements please consult our technical dept.

A	B	C	D	R	Weight/m	Chain
mm	mm	mm	mm	mm	kg	Part Number
82	75	38	57	135-150-180-200-230-280-300-400-600	2,46	308SU038 □□□ *
93	75	49	57	135-150-180-200-230-280-300-400-600	2,46	308SU049 □□□ *
107	75	63	57	135-150-180-200-230-280-300-400-600	2,51	308SU063 □□□ *
113	75	69	57	135-150-180-200-230-280-300-400-600	2,53	308SU069 □□□ *
117	75	73	57	135-150-180-200-230-280-300-400-600	2,54	308SU073 □□□ *
127	75	83	57	135-150-180-200-230-280-300-400-600	2,56	308SU083 □□□ *
132	75	88	57	135-150-180-200-230-280-300-400-600	2,56	308SU088 □□□ *
139	75	95	57	135-150-180-200-230-280-300-400-600	2,58	308SU095 □□□ *
149	75	105	57	135-150-180-200-230-280-300-400-600	2,59	308SU105 □□□ *
157	75	113	57	135-150-180-200-230-280-300-400-600	2,62	308SU113 □□□ *
168	75	124	57	135-150-180-200-230-280-300-400-600	2,65	308SU124 □□□ *
182	75	138	57	135-150-180-200-230-280-300-400-600	2,67	308SU138 □□□ *
207	75	163	57	135-150-180-200-230-280-300-400-600	2,73	308SU163 □□□ *
232	75	188	57	135-150-180-200-230-280-300-400-600	2,79	308SU188 □□□ *
243	75	199	57	135-150-180-200-230-280-300-400-600	2,81	308SU199 □□□ *
257	75	213	57	135-150-180-200-230-280-300-400-600	2,84	308SU213 □□□ *
284	75	240	57	135-150-180-200-230-280-300-400-600	2,90	308SU240 □□□ *
293	75	249	57	135-150-180-200-230-280-300-400-600	2,92	308SU249 □□□ *
318	75	274	57	135-150-180-200-230-280-300-400-600	2,99	308SU274 □□□ *
344	75	300	57	135-150-180-200-230-280-300-400-600	3,02	308SU300 □□□ *
366	75	322	57	135-150-180-200-230-280-300-400-600	3,07	308SU322 □□□ *
394	75	350	57	135-150-180-200-230-280-300-400-600	3,13	308SU350 □□□ *

\*Complete the code by inserting the value of the radius (R): Ex. 308SU105 □ □ □ □  
Chain equipped with nylon frame every pitch: complete the code by inserting the letter D.  
Ex. 308SU105150 □ □

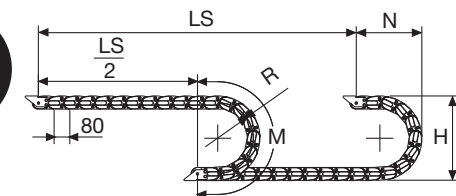

Length of chain (L)  
Half travel distance ( $\frac{LS}{2}$ )  
plus length of curve (M)

$$L = \frac{LS}{2} + M$$

R	H	N	M
mm	mm	mm	mm
135	345	255	585
150	375	270	635
180	435	300	725
200	475	320	790
230	535	350	885
280	635	400	1040
300	675	420	1105
400	875	520	1420
600	1275	720	2045



Version with frames mounted on every pitch.

### Self-Supporting Capacity Diagram

The maximum length of the self-supporting capacity ( $\frac{LS}{2}$ ) in relationship to the weight of the cables and hoses contained per linear metre.

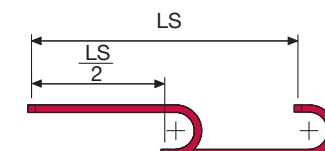
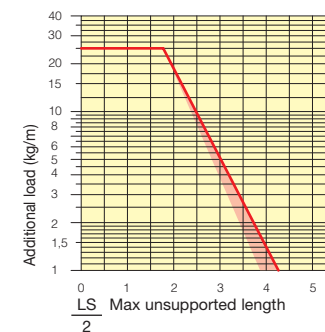

The red marking in the diagram area considers the difference of weight between various widths of chains assembled with nylon frames every second pitch.

For applications with  $\frac{LS}{2}$  and weights not included in the area of the diagram showing self-supporting capacity, verify the possible use of support rollers (see page 30).

### End Brackets

The end brackets set allows the two ends of the chain to be attached to the equipment. Set complete with tiwrap clamps available on request.

#### Nylon Type

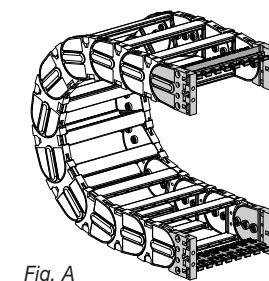
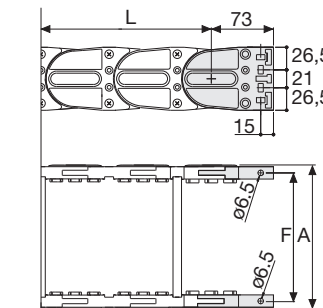

Fig. A The chain can be fixed frontally, inner or outer radius. (Fig A)



Chain Type	F mm
308SU038	62
308SU049	73
308SU063	87
308SU069	93
308SU073	97
308SU083	107
308SU088	112
308SU095	119
308SU105	129
308SU113	137
308SU124	148
308SU138	162
308SU163	187
308SU188	212
308SU199	223
308SU213	237
308SU240	264
308SU249	273
308SU274	298
308SU300	324
308SU322	346
308SU350	374

#### Nylon Type Part Numbers

Complete Set Assembled Chain Type	End Brackets Set
308SU...	AN308SKM

Complete Set Unassembled Chain Type	End Brackets Set
308SU...	AN308SK

Tiewrap Clamp Assembl.	CFC308S □□□ *KM
Unassembl.	CFC308S □□□ *K

#### Bright Zinc Plated Steel Type\*\*\*

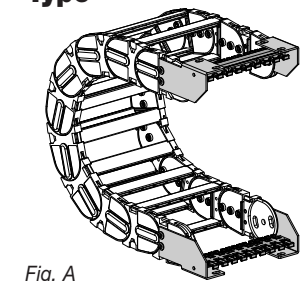
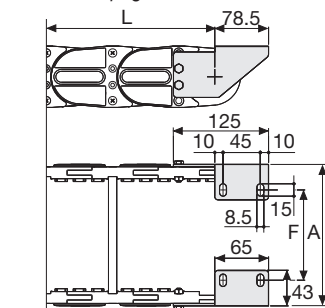

Fig. A Chain fixed outside the radius. (Fig A) See end brackets mounting variations page 31.



Chain Type	F mm
308SU038	-
308SU049	31
308SU063	45
308SU069	51
308SU073	55
308SU083	65
308SU088	70
308SU095	77
308SU105	87
308SU113	95
308SU124	106
308SU138	120
308SU163	145
308SU188	170
308SU199	181
308SU213	195
308SU240	222
308SU249	231
308SU274	256
308SU300	282
308SU322	304
308SU350	332

#### Bright Zinc Plated Steel Type Part Numbers

Complete Set Assembled Chain Type	End Brackets Set
308SU...	A308SKM □□**

Complete Set Unassembled Chain Type	End Brackets Set
308SU...	A308SK □□**

Tiewrap Clamp Assembl.	SFCT308S □□□ *KM
Unassembl.	SFCT308S □□□ *K

\* Inner width (C)  
\*\* 1=Pos.1; 2=Pos.2; 3=Pos.3  
\*\*\* Available on request in stainless steel

### Serie Heavy

## 308SU Nylon Cable Chain with opening frames

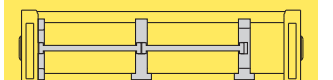

Separation System To choose the separators see page. 216

### How to open the cover.

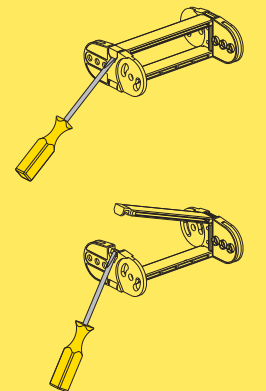

### Protection version



Protection version see page 152

For further information please consult Brevetti Stendalto's Technical Office