

306CU

Nylon Protection Cable Chain with opening aluminium covers

Inner height (D) 37 mm

Strong double share Sideband & Frame construction with large anti-friction triple-pin.

Covers are opening from inner and outer radius.

Vertical separators are available.

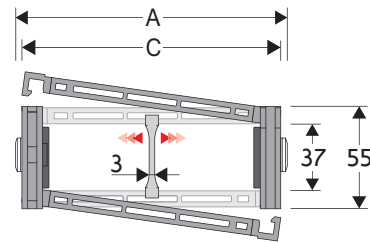

Separator

- Unassembled	Part.no S306SM
- Assembled	Part.no S306MMC

Pin

Part.no PG309H

Technical characteristics when self-supported

Speed	8 m/s
Acceleration	40 m/s ²

For higher requirements please consult our technical dept.

A	B	C	D	R	Weight/m	Chain
mm	mm	mm	mm	mm	kg	Part Number
79	55	43	37	107-150-200-250-300	1,85	306CU043 □□□ *
90	55	54	37	107-150-200-250-300	1,90	306CU054 □□□ *
104	55	68	37	107-150-200-250-300	2,04	306CU068 □□□ *
110	55	74	37	107-150-200-250-300	2,09	306CU074 □□□ *
114	55	78	37	107-150-200-250-300	2,15	306CU078 □□□ *
124	55	88	37	107-150-200-250-300	2,20	306CU088 □□□ *
129	55	93	37	107-150-200-250-300	2,22	306CU093 □□□ *
136	55	100	37	107-150-200-250-300	2,27	306CU100 □□□ *
146	55	110	37	107-150-200-250-300	2,33	306CU110 □□□ *
154	55	118	37	107-150-200-250-300	2,42	306CU118 □□□ *
165	55	129	37	107-150-200-250-300	2,50	306CU129 □□□ *
179	55	143	37	107-150-200-250-300	2,61	306CU143 □□□ *
204	55	168	37	107-150-200-250-300	2,80	306CU168 □□□ *
229	55	193	37	107-150-200-250-300	3,00	306CU193 □□□ *
240	55	204	37	107-150-200-250-300	3,08	306CU204 □□□ *
254	55	218	37	107-150-200-250-300	3,19	306CU218 □□□ *
281	55	245	37	107-150-200-250-300	3,40	306CU245 □□□ *
290	55	254	37	107-150-200-250-300	3,47	306CU254 □□□ *
315	55	279	37	107-150-200-250-300	3,77	306CU279 □□□ *
341	55	305	37	107-150-200-250-300	3,84	306CU305 □□□ *
363	55	327	37	107-150-200-250-300	4,01	306CU327 □□□ *
391	55	355	37	107-150-200-250-300	4,22	306CU355 □□□ *

*Complete the code by inserting the value of the radius (R): Ex. 306CU110 □ □ □ □ □

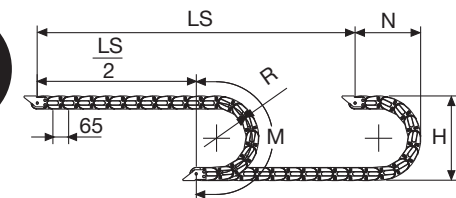

Length of chain (L)
Half travel distance ($\frac{LS}{2}$)
plus length of curve (M)

$$L = \frac{LS}{2} + M$$

R	H	N	M
mm	mm	mm	mm
107	272	205	470
150	358	245	605
200	458	295	760
250	558	345	920
300	658	395	1075

Self-Supporting Capacity Diagram

The maximum length of the self-supporting capacity ($\frac{LS}{2}$) in relationship to the weight of the cables and hoses contained per linear metre.

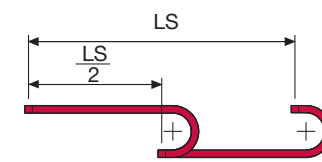
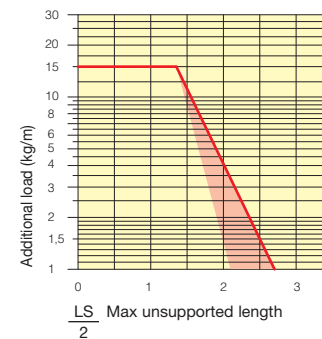

The red marking in the diagram area considers the difference of weight between various widths of chains assembled with nylon frames every second pitch.

For applications with $\frac{LS}{2}$ and weights not included in the area of the diagram showing self-supporting capacity, verify the possible use of support rollers (see page 30).

End Brackets

The end brackets set allows the two ends of the chain to be attached to the equipment. Set complete with tiwrap clamps available on request.

Nylon Type

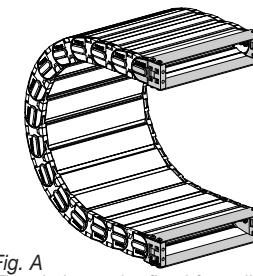

Fig. A The chain can be fixed frontally, inner or outer radius. (Fig A)

Nylon Type

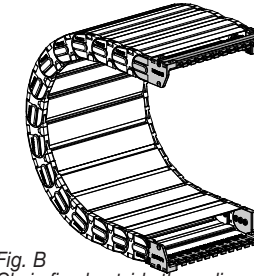
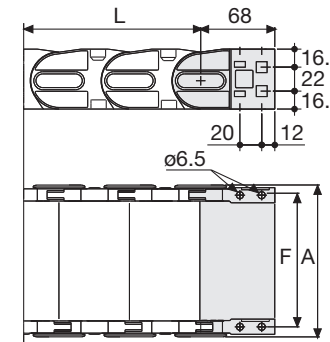

Fig. B Chain fixed outside the radius. (Fig B) See end brackets mounting variations page 31.



Chain Type	F mm
306CU043	61
306CU054	72
306CU068	86
306CU074	92
306CU078	96
306CU088	106
306CU093	111
306CU100	118
306CU110	128
306CU118	136
306CU129	147
306CU143	161
306CU168	186
306CU193	211
306CU204	222
306CU218	236
306CU245	263
306CU254	272
306CU279	297
306CU305	323
306CU327	345
306CU355	373

Nylon Type Part Numbers

Complete Set Assembled Chain Type	End Brackets Set
306	AN306C□□□*KM
Complete Set Unassembled Chain Type	End Brackets Set
306	AN306C□□□*K

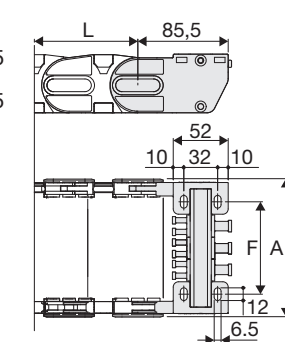

Chain Type	F mm
306CU043	36
306CU054	47
306CU068	61
306CU074	67
306CU078	71
306CU088	81
306CU093	86
306CU100	93
306CU110	103
306CU118	111
306CU129	122
306CU143	136
306CU168	161
306CU193	186
306CU204	197
306CU218	211
306CU245	238
306CU254	247
306CU279	272
306CU305	298
306CU327	320
306CU355	348

Nylon Type Part Numbers

Complete Set Assembled Chain Type	End Brackets Set
306	ANL306KM□□**
Complete Set Unassembled Chain Type	End Brackets Set
306	ANL306K□□**

Tiewrap Clamp
Assembl. SFCTL306□□□*KM
Unassembl. SFCTL306S□□□*K
SFCTL not applicable for C=43

306CU Nylon Protection Cable Chain with opening aluminium covers

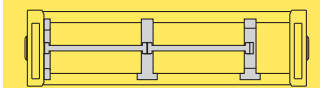

Separation System To choose the separators see page. 216

Bright Zinc Plated Steel Type***

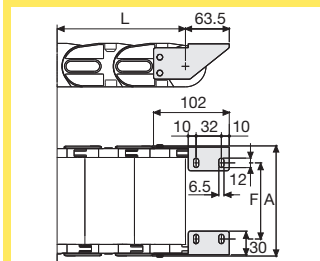
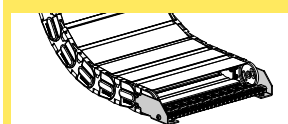

F = A-43

Bright Zinc Plated Steel Type Part Numbers

Complete Set Assembled Chain Type	End Brackets Set
306	A306CU□□□*KM□□**
Complete Set Unassembled Chain Type	End Brackets Set
306	A306CU□□□*K□□**
Tiewrap Clamp	
Assembl. SFCT306S□□□*KM	
Unassembl. SFCT306S□□□*K	

* Inner width (C)
** 1=Pos.1; 2=Pos.2; 3=Pos.3
*** Available on request in stainless steel