

305A Nylon Cable Chain with removable frames

Inner height (D) 24 mm

Double share single link joining construction with large anti-friction single-pin. Frames removable from inner radius. Vertical separators are available. Wide frames on outer radius offer good protection. Due to its design with double-share lateral side, the chain is very robust, meanwhile offering very low friction.

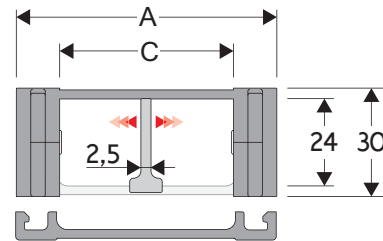

Separator	
- Unassembled	Part.no S305A
- Assembled	Part.no S305AMC
Pin	
	Part.no PG305

Technical characteristics when self-supported

Speed	10 m/s
Acceleration	50 m/s ²

For higher requirements please consult our technical dept.

A	B	C	D	R	Weight/m	Chain
mm	mm	mm	mm	mm	kg	Part Number
54	30	30	24	50	0,85	305A008
54	30	30	24	70	0,85	305A010
54	30	30	24	120	0,85	305A020
54	30	30	24	150	0,85	305A050
74	30	50	24	50	0,95	305A009
74	30	50	24	70	0,95	305A030
74	30	50	24	120	0,95	305A040
74	30	50	24	150	0,95	305A060

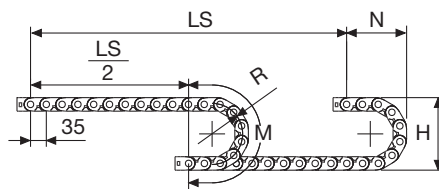

Length of chain (L)
Half travel distance ($\frac{LS}{2}$)
plus length of curve (M)

$$L = \frac{LS}{2} + M$$

R	H	N	M
mm	mm	mm	mm
50	130	105	230
70	170	120	290
120	270	175	450
150	330	205	545

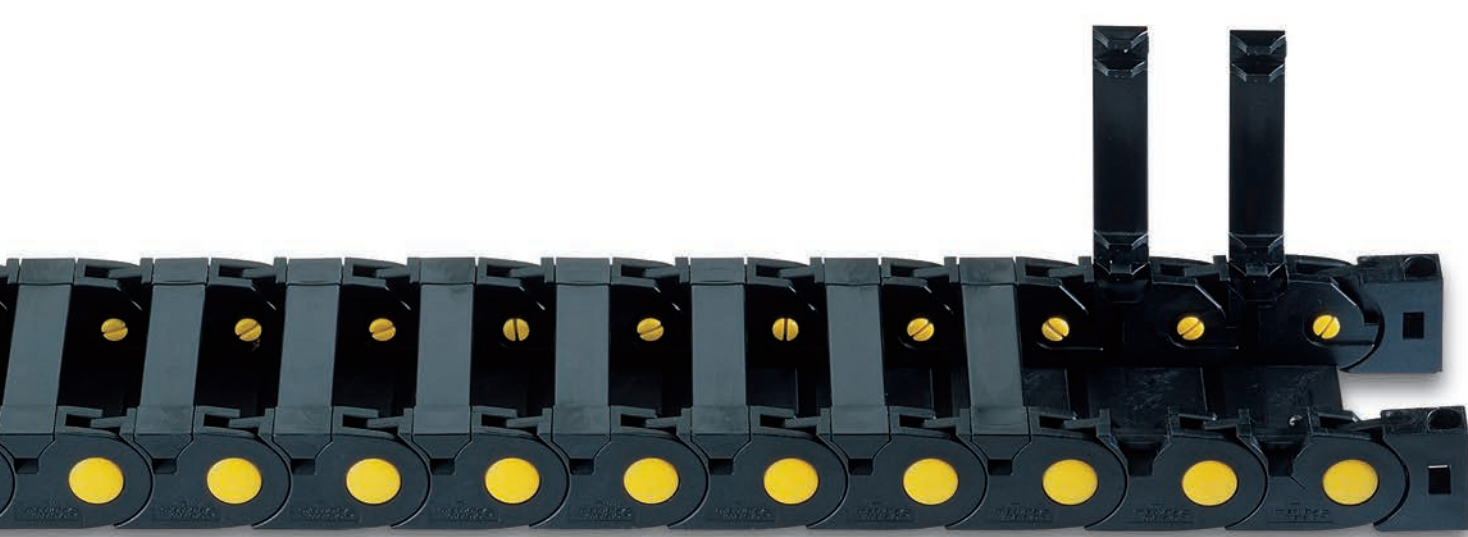

Self-Supporting Capacity Diagram

The maximum length of the self-supporting capacity ($\frac{LS}{2}$) in relationship to the weight of the cables and hoses contained per linear metre.

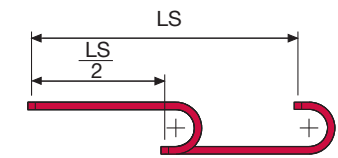
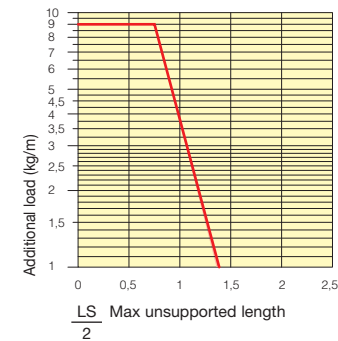

The red marking in the diagram area considers the difference of weight between various widths of chain.

For applications with $\frac{LS}{2}$ and weights not included in the area of the diagram showing self-supporting capacity, verify the possible use of support rollers (see page 30).

End Brackets

The end brackets set allows the two ends of the chain to be attached to the equipment.

Nylon Type

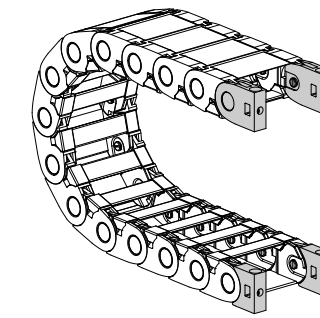

Fig. A
The chain can be fixed frontally, inner or outer radius. (Fig A)

Bright Zinc Plated Steel Type***

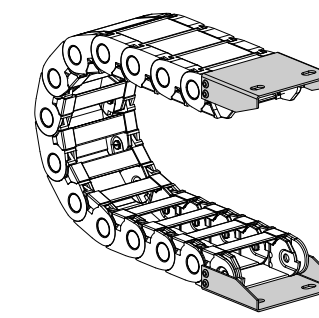
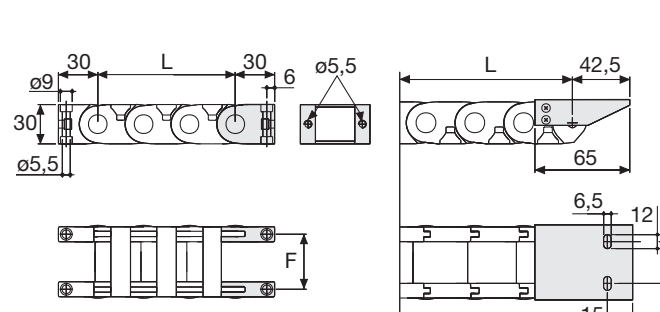

Fig. B
Chain fixed outside the radius. (Fig B)
See end brackets mounting variations page 31.



Chain Type	F mm
305A C=30	42,5
305A C=50	62,5

Chain Type	F mm
305A C=30	30,5
305A C=50	50,5

Nylon Type Part Numbers

Complete Set Assembled	End Brackets
Chain Type	Set
305A C=30	AN305KM
305A C=50	AN305KM

Complete Set Unassembled	End Brackets
Chain Type	Set
305A C=30	AN305K
305A C=50	AN305K

Bright Zinc Plated Steel Type Part Numbers

Complete Set Assembled	End Brackets
Chain Type	Set
305A C=30	AP305AKM1
305A C=50	AG305AKM1

Complete Set Unassembled	End Brackets
Chain Type	Set
305A C=30	AP305AK1
305A C=50	AG305AK1

*** Available on request in stainless steel

305A Nylon Cable Chain with removable frames



How to open the cover.

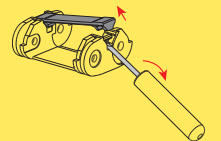
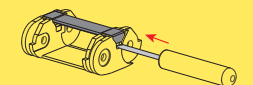

Special tool to remove the connecting pivots: Part Number PZ010.



For further information please consult Brevetti Standalto's Technical Office